

**THE WIND THAT SHAKES THE BARLEY** (R8x32) 3C (4C set) John M Duthie 8 SCDs

1- 8 1s lead down for 3 steps, lead back to top of set and cast into 2nd place on own sides  
9-16 1s dance reels of 3 across, (1M with 2s and 1L with 3s), RSh to 2nd corner  
17-24 1s turn 1st corner, partner, 2nd corner, partner  
25-32 All circle 6H round and back

**ECCLFECHAN FELINE** (J8x32) 3C (4C set) Bob McMurtry Le Petit Chat Celtique

1- 8 1s dance Fig of 8 on own sides (1s dance in/down to start), taking nearer hands where possible  
9-16 1s+2s+3s mirror (reflection) reels on own sides (1s in/down, 2s out/up, 3s in/up to start)  
17-24 1s lead down (3 bars), lead back up (3 bars) cast into 2nd place own sides  
25-32 1M with 3s, 1L with 2s, dance RH across, 1s pass RSh to dance LH across other end (1M with 2s, 1L with 3s)

**TRIPLE HAPPINESS** (S3x32) 3C Yoshiki Oyama RSCDS Book 52

1- 8 1s advance and retire (1 step each) taking RH briefly, 1s ½ turn LH, cross down between 2s and cast up to place  
9-16 1s+2s dance the Knot. 1s end facing 1st corners  
17-24 1s dance Corners pass and turn with 1st corners, pass RSh, Repeat with 2nd corners and 1s pass RSh into 2nd place own sides (corners turn 2H in centre)  
25-32 All chase clockwise ½ round to opposite sides, all ½ turn 2H, pull back RSh and dance out to own sides. 312

**THE HIGHLANDMAN'S UMBRELLA** (R4x32) Sq.Set Anna C Holden Glasgow Diamond Jubilee

1- 8 All 4 couples in prom hold advance 2 steps to centre and retire, all Ladies cast 1 place clockwise  
9-16 All with new partners advance and retire, all Men cast 1 place anticlockwise  
17-24 All set to new partners, 1M+3M change places LH (across set), 2M+4M change places LH (up/down set) and all set to own partners  
25-32 All circle 8H round and back

**HOOPER'S JIG** (J8x32) 3C (4C set) MMM 2

1- 8 All clap and 1s cross passing RSh, cast to 2nd place and dance RH across with 3s  
9-16 All clap and 1s cross passing RSh, cast to 1st place and dance LH across with 2s  
17-24 1M+3L change places RH and 1L+3M change places RH (as 1M+3L loop round), 1M+3L change places RH (as 1L+3M loop round) and 1L+3M cross LH 1L ending in 2nd place (as 1M casts to 2nd place), 2s step up on bars 23-24  
25-32 2s+1s dance R&L. 213

**GANG THE SAME GATE** (S8x32) 3C (4C set) Milton Levy RSCDS Book 36

1- 8 1s cross RH and cast down to 3rd place, cross RH and cast up to 2nd place on own sides  
9-16 1s set advancing to partner and turn 1st corner 2H to face 2nd corner, 1s dance ½ diagonal reel of 4 ending M between top couple facing down and L between bottom couple facing up  
17-24 1s set advancing to partner and turn 4th corner (position) 2H to face own 1st corner (position), 1s dance ½ diagonal reel with 1st corners ending in 2nd place opposite sides  
25-32 3s+1s+2s set and link for 3 twice. 213

**LES REMPARTS DE SÉVILLE** (J8x32) 3C (4C set) Aliénor Latour RSCDS Book 50

1- 8 1s set, cast (2s step up bars 3-4), 1s dance ½ Figs 8, 1L round 2s, 1M round 3s  
 9-16 1s turn LH to face 1st corners and dance set to corners and partner ('Hello-Goodbye') to end  
 1M between 2s facing down, 1L between 3s facing up  
 17-24 2s+1s+3s set and link, all set, all cross RH  
 25-32 2s+1s+3s circle 6H round and back

**THE BLACK HAIRD LASSIE** (R8x32) 3C (4C set) Carolyn Hunt Let's All Dance Too

1- 8 1s dance reflection (mirror) reels of 3 on own sides (1s in and down to start)  
 9-16 1s cross RH and cast 1 place, 1s dance ½ Fig of 8 round 2s to end facing 1st corners  
 17-24 1s turn corners RH and passing RSh to face 2nd corners, 1s turn corners RH and pass partner  
 RSh to 2nd place own sides  
 25-32 2s+1s+3s circle 6H round and back

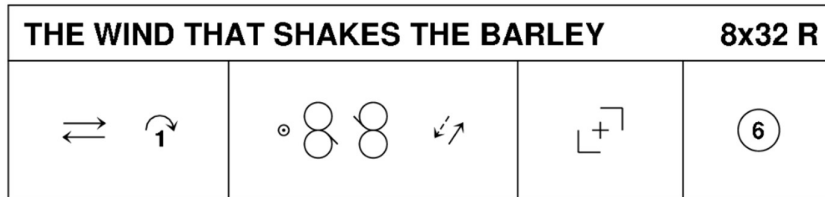

John M Duthie, 1961, Eight SCD

3C/4C longwise set.

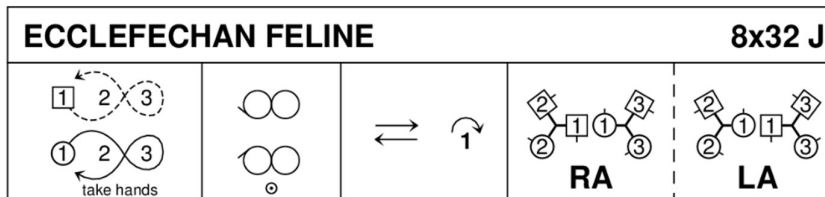

Bob McMurtry, Le Petit Chat Celtique

3C/4C longwise set

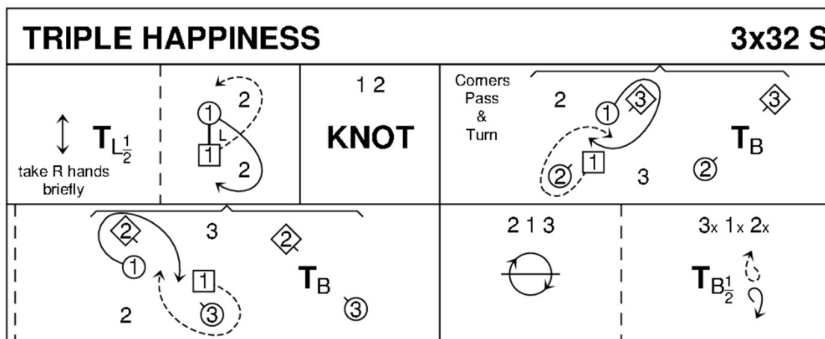

Yoshiki Oyama, 2016, RSCDS Book 52.10

3C/3C longwise set.

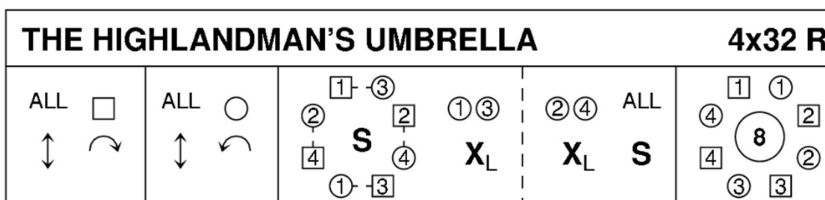

Anna Holden, Collins Pocket SCD

4C/4C square set.

<b>HOOPER'S JIG</b>				<b>8x32 J</b>	
ALL	1x 3	ALL	1 2	1 2 3	2 1
※ ↑ ↓ ↻ 1	RA	※ ↑ ↓ ↻ 1	LA	X <sub>R</sub> X <sub>R</sub> X <sub>R</sub> X <sub>L</sub>	RL
RSCDS MMM (34), RSCDS Thirty Popular Dances Vol 2				3C/4C longwise set.	

<b>GANG THE SAME GATE</b>				<b>8x32 S</b>	
X <sub>R</sub> 2	X <sub>R</sub> 1	S ↑ T <sub>B</sub>		3 3	
Set and Link for Three					
Milton Levy, RSCDS Book 36.4				3C/4C longwise set.	

<b>LES REMPARTS DE SÉVILLE</b>				<b>8x32 J</b>	
S 1		1x T <sub>L</sub> S	1x S S		2x 1x 3x
				S & Link	S X <sub>R</sub>
				6	
Aliénor Latour, 2014, RSCDS Book 50.2				3C/4C longwise set.	

<b>THE BLACK-HAIRED LASSIE</b>				<b>8x32 R</b>	
	X <sub>R</sub> 1		T <sub>R</sub>	T <sub>R</sub>	2 1 3
				6	
Carolyn Hunt, 1993, Let's All Dance Too				3C/4C longwise set.	