

THE EDINBURGH TOY SHOP (J8x32) 3C (4C set) Ethan Bailey RSCDS Book 51

1- 8 1s set, dance down and cast up round 3s (2s step up 3-4), 2s+1s+3s set
9-16 ½ Fig of 8 (1L round 2M, 1M round 3L) to 2nd place opposite sides, 2s+1s+3s set and 1s turn LH to face 1st corners
17-24 1s turn 1st corner RH, pass partner RSh, turn 2nd corner RH, pass partner RSh to 2nd place own sides
25-32 2s+1s+3s circle 6H round and back

MARY ERSKINE (R8x32) 3C (4C set) Roy Goldring 15 Social Dances

1- 8 1s+2s turn on sides 1½ times (Men RH and Ladies LH), 1s cast down behind 3s, meet and dance up to 2nd place facing own sides ready for...
9-16 1s dance Double Triangles, end by turning right about to face each other (remaining in middle)
17-24 1s slip step down centre and back
25-32 1L dances LH across on Men's side as 1M dances RH across on Ladies' side and dance ½ Fig of 8 round 2s

THE RED ROSE (S4x32) Sq.Set Margaret Shearer (2016) RSCDS Dunfermline 90th Anniv Dances (3)

1- 8 Ladies dance RH across, dance LSh round partner to place and all set
9-16 Men dance LH across, dance RSh round partner to place and all set
17-24 Ladies petronella turn 1 place to right (anticlockwise) and all set; Men petronella turn 1 place to right and all set
25-32 All circle 8H round and back. 2341

GOOD HEARTED GLASGOW (J8x32) 3C (4C set) Peter Knapman Guide To SCD (ex-Collins)

1- 8 1s turn RH and cast to 2nd place, turn partner LH 1¼ times
9-16 1s dance RH across (Lady with 2s at top and Man with 3s); 1s pass RSh and dance LH across with other couple
17-24 1s lead down the middle and back to 2nd place own side
25-32 2s+1s+3s circle 6H round and back. 213

HOLDEN LANE (R8x32) 3C (4C set) Anna C Holden Brock Summer Celebration

1- 8 1s cross down below 2s, cast down round 3s, ½ turn RH and lead up to BtoB position for double triangles
9-16 1s dance Double Triangles ending 2nd place own sides
17-24 1M followed by partner casts up round 2M and dances down centre, 1M between 3s and 1L between 2s all dance down in lines of 3 and turn right about
25-32 All dance up 1L turning to face down to partner, 1s turn RH 1¼ times to 2nd places

LATE IN THE DAY (R8x40) 3C (4C set) John Bowie Dickson Dunedin Dances Book 5

1- 8 1s set and cross down RH, set and ¾ turn LH to face 1st corners
9-16 1s dance ½ diagonal reel with 1st corners, pass RSh and dance pass and turn with 2nd corners
17-24 1s dance pass and turn with 3rd corner (positions) and ½ diagonal reel with 4th corner (positions)
25-32 1s dance RH across (1L with 3s at top and 1M with 2s) end in 2nd place opposite sides and chase clockwise ½ way
33-40 2s+1s+3s circle 6H round and back

FRIENDSHIPS (S4x32) 4C set Jennie Miller RSCDS Graded 3

1- 8 1s+3s dance down between 2s/4s and cast back to places, 1s+2s also 3s+4s dance circle 4H round to Left
9-16 2s+4s dance up between 1s/3s and cast back to places. 1s+2s also 3s+4s dance circle 4H round to Right
17-24 1s+2s set, ½ RH across. 1s+3s set, ½ LH across
25-32 1s+4s set, ½ RH across. All 4 couples set and cross RH

FAREWELL TO BALFOUR ROAD (J1x96) 5C set Andrew Buxton RSCDS Book 52

1- 8 1s+2s circle 4H round and back
9-16 1s+2s set and link; 1s+3s set and link
17-24 *2s start* while 1s+4s+5s dance mirror reels of 3 on sides (1s in/down, 5s in/up to start)
25-32 1s set, cross down RH to 4th place (4s step up); 1s set, cross down LH to 5th place (5s step up)
New top couple start every 16 bars. Repeat until 1s back in 1st place, they stand for 16 bars while 5s continue bars 17-32 ending back in 5th place

TOAST TO THE MOUSIES (R8X32) 3C (4C set) Sara Gratiot RSCDS book 53

1- 8 1s dance in and cast 1 place (2s step up), dance down between 3s and cast up to 2nd place
9-16 2s+1L also 1M+3s dance RH across and 1s pass RSh to dance LH across with other couple, 1s end back to back in the middle (1M facing up, 1L down) facing 2s/3s (2s facing down, 3s up nearer hands joined)
17-20 All set, 2s and 3s make arches, dance down/up to meet as 1s dance under arches. Finish 1M in 1st place, 1L in 3rd place (facing down/up) and 2s and 3s back to back in middle nearer hands joined (2s facing up, 3s down).
21-24 All set, 2s and 3s making arches dance to ends and cast into reel while 1s dance under arch passing LSh and finish between end couple facing 1st corner
25-32 2s+1L also 1M+3s dance LSh reels across (2s+3s make loops into the reel) to end 213. All set

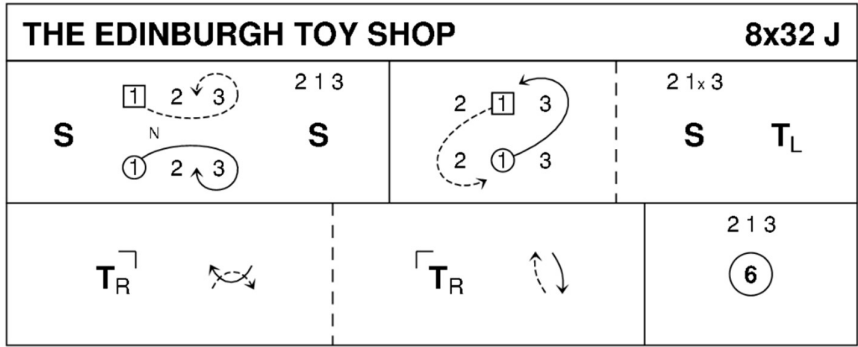

Ethan Bailey, 2016, RSCDS Book 51

3C/4C longwise set.

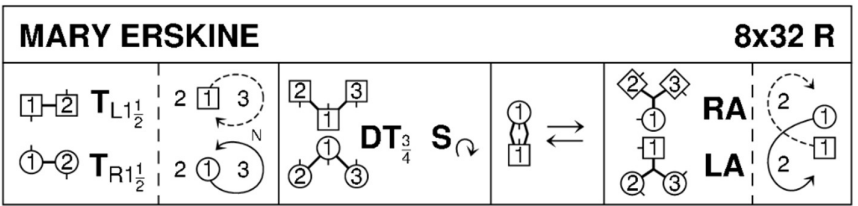

Roy Goldring, 1994, 15 Social Dances, RSCDS Graded Book 2.15

3C/4C longwise set.

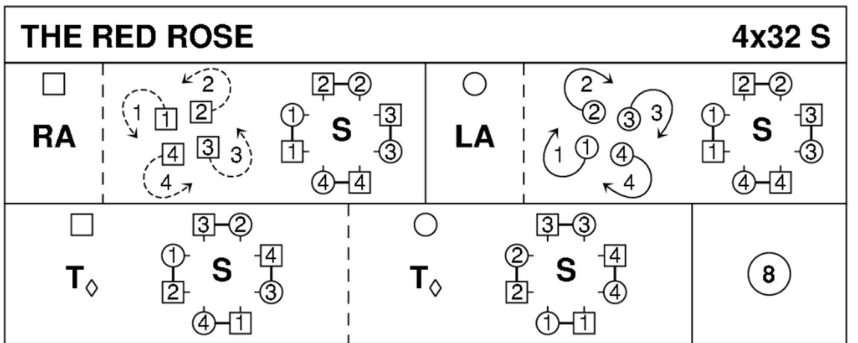

Margaret Shearer, 2016, RSCDS Dunfermline 90th Anniversary

4C/4C square set.

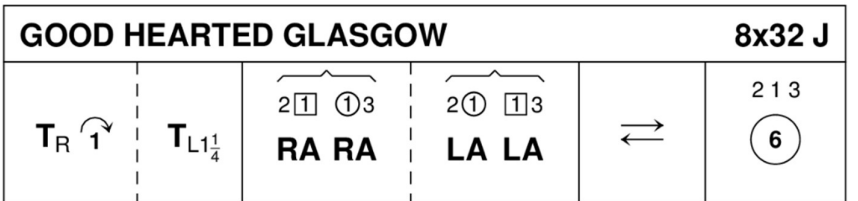



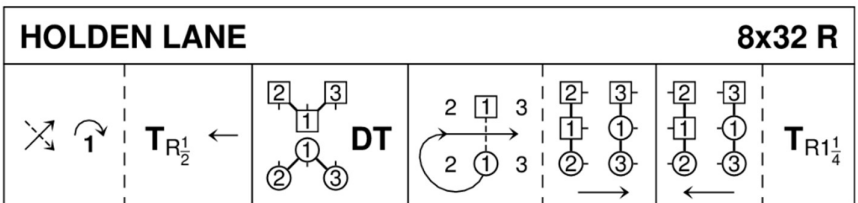

Peter Knapman, 1988, Collins Pocket Reference

3C/4C longwise set.

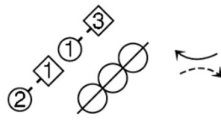
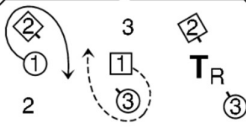
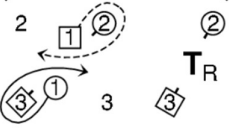
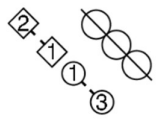
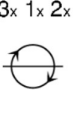

Anna Holden, Brock Summer Celebration

3C/4C longwise set

LATE IN THE DAY		8x40 R	
 S	 ST	 Corners Pass & Turn	 T_R
 T_R	 RA	 3x 1x 2x	 2 1 3 6

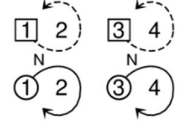
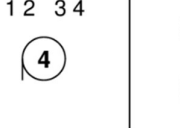
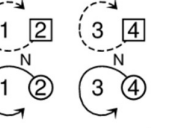
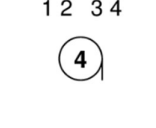
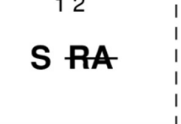
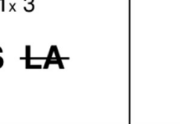
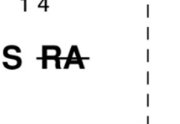
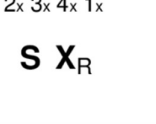

John Bowie Dickson, 1997, Dunedin Dances 5.22

3C/4C longwise set.

FRIENDSHIPS		4x32 S	
			
 1 2 S RA	 1x 3 S LA	 1 4 S RA	 2x 3x 4x 1x S X_R



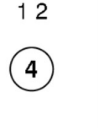
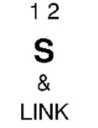
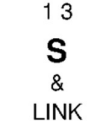

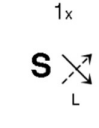
Jennie Miller, RSCDS Graded Book 3.3

4C/4C longwise set.

FAREWELL TO BALFOUR ROAD				96 J	
5 couples, 2C start on bar 17					
 1 2 4	 1 2 S & LINK	 1 3 S & LINK	 1 4 5	 S	 1x S

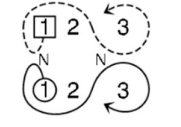
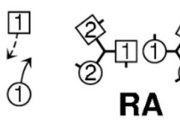
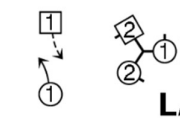
Andrew Buxton, 2015, RSCDS Book 52.7

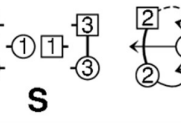
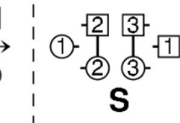
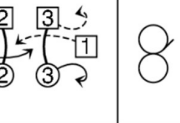
5C/5C longwise set.

TOAST TO THE MOUSIES		8x32 R	
	 RA	 LA	
 S	 S		 2 1 3 S

Sara Gratiot, 2016, RSCDS Book 53

3C/4C longwise set.